

# Conductive Elastomer Gasket Design\*

## Gasket Junction Design

The ideal gasketing surface is rigid and recessed to completely house the gasket. Moreover, it should be as conductive as possible. Metal surfaces mating with the gasket ideally should be non-corrosive. Where reaction with the environment is inevitable, the reaction products should be electrically conductive or easily penetrable by mechanical abrasion. It is here that many gasket designs fail. The designer could not, or did not treat the mating surface with the same care as that given to the selection of the gasketing material.

By definition, a gasket is necessary only where an imperfect surface exists. If the junction were perfect, which includes either a solidly welded closure, or one with mating surfaces infinitely stiff, perfectly flat, or with infinite conductivity across the junction, no gasket would be necessary. The more imperfect the mating surfaces, the more critical is the function of the gasket. Perfect surfaces are expensive. The final solution is generally a compromise between economics and performance, but it should not be at the expense of neglecting the design of the flange surfaces.

The important property that makes a *conductive elastomer* gasket a good EMI/EMP seal is its ability to provide good electrical conductivity across the gasket-flange interface. Generally, the better the conformability and conductivity, the higher the shielding effectiveness of the gasket. In practice, it has been found that surface conductivity of both the gasket and the mating surfaces is the single most important property that makes the gasketed seam effective; i.e., *the resistance between the flange and gasket should be as low as possible.*

At this stage of the design every effort should be given to choosing a flange that will be as stiff as possible consistent with the construction used and within the other design constraints.

### 1. Flange Materials

Flanges are generally made of the same material as the basic enclosure for reasons of economy, weldability, strength and resistance to corrosion. Wherever possible, the flanges should be made of materials with the highest possible conductivity. It is advisable to add caution notes on drawings not to paint the flange mating surfaces. If paint is to be applied to outside surfaces, be sure that the contact surfaces are well masked before paint is applied, and then cleaned after the masking tape is removed. If the assembled units are subject to painting or repainting in the field, add a cautionary note in a conspicuous location adjacent to the seal that the seal areas are to be masked before painting.

Ordinarily, the higher the conductivity of a material, the more readily it oxidizes – except for noble metals such as gold and silver. Gold is impervious to oxidation, and silver, although it oxidizes, forms oxides that are soft and relatively conductive.

Most oxides, however, are hard. Some of the oxide layers remain thin while others build up to substantial thickness in relatively short time. These oxides form insulating, or semi-conducting films at the boundary between the gasket and the flanges. This effect can be overcome to a degree by using materials that do not oxidize readily, or by coating the surface with a conductive material that is less subject to oxidation. Nickel plating is generally recommended for aluminum parts, although tin has

become widely accepted. Zinc is primarily used with steel. Consult the applicable specifications before selecting a finish. A good guide to finishing EMI shielded flanges for aerospace applications has been published by SAE Committee AE-4 (Electromagnetic Compatibility) under the designation ARP 1481. A discussion of corrosion control follows later in this guide.

### 2. Advantages of Grooved Designs

All rubber materials are subject to “Compression Set,” especially if over compressed. Because flange surfaces cannot be held uniformly flat when the bolts are tightened (unless the flanges are infinitely stiff), gaskets tend to overcompress in the areas of the bolts. Proper groove design is required to avoid this problem of over compression. A groove also provides metal-to-metal contact between the flange members, thereby reducing contact resistance across the junction.

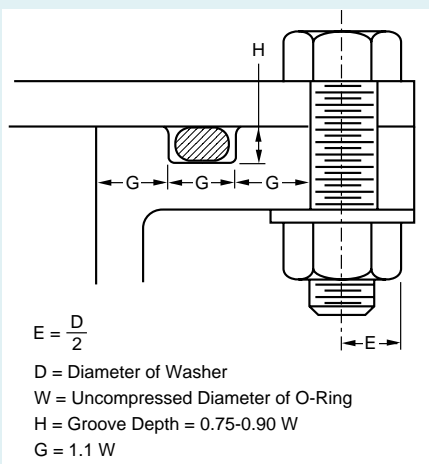
A single groove will suffice for most designs. Adding a second groove parallel to the first adds approximately 6 dB to the overall performance of a single-groove design. Adding more grooves beyond the second does not increase the gasketing effectiveness significantly.

### 3. Flange Design Considerations

Most designers fight a space limitation, particularly in the vicinity of the gasketed seam. Complex fasteners are often required to make the junctions more compact.

The ideal flange includes a groove for limiting the deflection of a gasket. The screw or bolt fasteners are mounted outboard of the gasket to eliminate the need for providing gaskets under the fasteners. A machined flange and its recommended groove dimensions are shown in Figure 10. The gasket may

\* Complete solid-O gasket design information starts on page 209.



**Figure 10** Machined Flange with Gasket Groove

be an “O” or “D”-shaped gasket, either solid or hollow.

Solid conductive O-rings are normally limited to a deflection of 25 percent. Therefore, the minimum compressed height of the O-ring (also the groove depth) is related to the uncompressed height (or diameter) by the expression  $H = 0.75 W$ , where W is the uncompressed diameter. The width of the groove, G, should be equal to 1.1 W. Allow sufficient void in the groove area to provide for a maximum gasket fill of 95 percent. Conductive elastomer gaskets may be thought of as “incompressible fluids.” For this reason, sufficient groove cross sectional area must be allowed for the largest cross-sectional area of the gasket when tolerances are taken into account. Never allow groove and gasket tolerance accumulations to cause an “over-filled” groove (see gasket tolerances in section which follows).

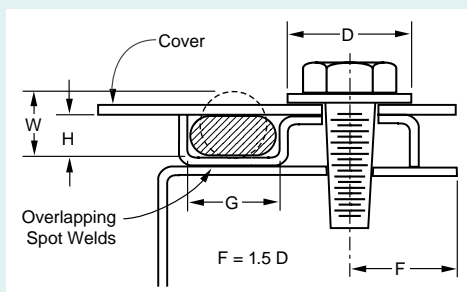
When a seal is used to isolate pressure environments in addition to EMI, the bottom of the gasket groove should have a surface finish of 32-64  $\mu\text{in.}$  (RMS) to minimize leakage along the grooves. Avoid machining

methods that produce longitudinal (circumferential) scratches or chatter marks. Conversely, a surface that is too smooth will cause the gasket to “roll over” or twist in its groove.

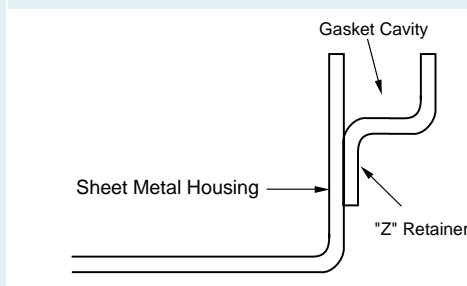
The minimum distance from the edge of the groove to the nearest terminal edge, whether this terminal be the edge of a casting, a change in cross section, or a fastening device, should be equal to the groove width, G.

Bolts should be located a minimum distance, E (equal to one-half the diameter of the washer used under the head of the bolt) from the edge of the flange.

Square or rectangular cross section gaskets can be used in the same groove provided sufficient void is allowed for displacement of the rubber. A good design practice is not to allow the height of the gasket to exceed the base width. A better, or a more optimum ratio is a height-to-width ratio of one-half. Tall gaskets tend to roll over when loaded.



**Figure 11a** Shaped Sheet Metal Container



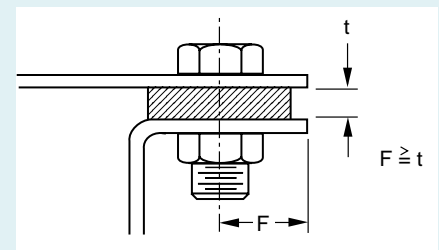
**Figure 11b** Z-Retainer Forms Gasket Cavity

The thickness of a flange is governed by the stiffness required to prevent excessive bowing between fastener points. Fewer, but larger bolts, require a thicker flange to prevent excessive deflections. For calculations of elastic deformation, refer to pages 206 and 207.

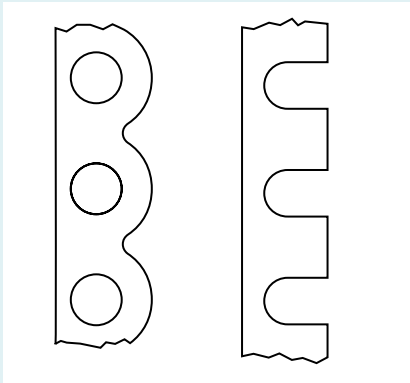
O-shaped and D-shaped gaskets may also be used in sheet metal flanges. The gaskets can be retained in a U-channel or Z-retainer, and are deflection-limited by adjusting the channel or retainer dimensions with respect to gasket height. Suggested retainer configurations are shown in Figures 11a and 11b.

A basic difference between flanges constructed from sheet metal and those which are machined from castings is that the bolts cannot be located as close to the edge of the part when the flange is made of sheet metal. Note, in Figure 11a, F is recommended to be 1.5 D, where D is the diameter of the washer.

Flat gaskets are ordinarily used with sheet metal or machined flanges as typically illustrated in Figure 12. Bolt holes in the flanges should be located at least 1.5 times the bolt diameter from the edge of the flange to prevent tearing when the metal is punched. If the holes are drilled, the position of the holes should be not less than the thickness of the gasket material from the edge of the flange. If holes must be placed closer to the edge than the recommended values, ears or



**Figure 12** Flat Gasket on Sheet Metal Flange



**Figure 13** Ears or Slots in Sheet Metal Flanges or Flat Gaskets

slots should be considered as shown in Figure 13. Holes in flat gaskets should be treated in a similar manner.

**4. Dimensional Tolerances**

Grooves should be held to a machined tolerance of  $\pm 0.002$  in. Holes drilled into machined parts should be held to within  $\pm 0.005$  in. with respect to hole location. Location of punched holes should be within  $\pm 0.010$  in. Sheet metal bends should be held to  $+0.030$  and  $-0.000$  in. Gasket tolerances are given in the “Selection of Seal Cross Section,” later in this guide.

**5. Waveguide Flanges**

The three concerns for waveguide flanges are to ensure maximum transfer of electromagnetic energy across the flange interface to prevent RF leakage from the interface, and to maintain pressurization of the waveguide. Conductive elastomeric gaskets provide both an electrical and a seal function. For flat cover flanges, a die-cut sheet gasket (CHO-SEAL 1239 material), incorporating expanded metal reinforcement to control gasket creep into the waveguide opening, provides an excellent seal. Raised lips around the gasket cut-out improve the power handling and pressure sealing capability of the gasket. Choke flanges are best

sealed with molded circular D-Section gaskets, and contact flanges with molded rectangular D-gaskets in a suitable groove (both in CHO-SEAL 1212 material).

The peak power handling capabilities of waveguide flanges are limited primarily by misalignment and sharp edges of flanges and/or gaskets. Average power handling is limited by the heating effects caused by contact resistance of the flange-gasket interface (“junction resistance”).

**Corrosion**

All metals are subject to corrosion. That is, metal has an innate tendency to react either chemically or electrochemically with its environment to form a compound which is stable in the environment.

Most electronic packages must be designed for one of four general environments:

**Class A. Controlled Environment** Temperature and humidity are controlled. General indoor, habitable exposure.

**Class B. Uncontrolled Environment** Temperature and humidity are not controlled. Exposed to humidities of 100 percent with occasional wetting. Outdoor

exposure or exposure in uncontrolled warehouses.

**Class C. Marine Environment** Shipboard exposure or land exposure within two miles of salt water where conditions of Class A are not met.

**Class D. Space Environment** Exposure to high vacuum and high radiation.

**Finishes**

Table I shows the minimum finish necessary to arrest chemical corrosion and provide an electrically conductive surface for the common metals of construction. Only the Class A, B, and C environments are shown in the table because the space environment is not a corrosive one (i.e., metals are not generally affected by the space environment).

Some metals require finishing because they chemically corrode. These are listed in Table I, and should be finished in accordance with the table. To select a proper finish for metals not given in Table I, refer to the material groupings of Table II. Adjacent groups in Table II are compatible. Another excellent source of information on corrosion-compatible finishes for EMI shielded

**Table I**

MINIMUM FINISH REQUIREMENTS FOR STRUCTURAL METALS			
Metal	ENVIRONMENT		
	Class A	Class B	Class C
Carbon and Alloy Steel	0.0003 in. cadmium plate 0.0005 in. zinc plate 0.0003 in. tin	0.0005 in. cadmium 0.001 in. zinc 0.0005 in. tin	0.003 in. nickel 0.001 in. tin
Corrosion-Resistant Steels	No finish required	No finish required; 0.0005 in. nickel to prevent tarnish	No finish required; 0.001 in. nickel to prevent tarnish
Aluminum 2000 & 7000 series	Chromate conversion coat (MIL-C-5541, Class 3)	Chromate conversion coat (MIL-C-5541) plus conductive epoxy or urethane	0.001 in. tin
Aluminum 3000, 5000, 6000 series and clad	No finish required, unless shielding requirements are high (see above)	Chromate conversion coat	Chromate conversion coat plus conductive epoxy or urethane
Copper and Copper Alloys	0.0003 in. tin	0.0005 in. tin	0.003 in. nickel 0.001 in. tin
Magnesium	0.0003 in. tin	0.0005 in. tin	0.001 in. tin
Zinc Base Castings	No finish required	0.0003 in. tin	0.0005 in. tin

**Table II**

METALS COMPATIBILITY	
Group	Material Groupings*
1	Gold – Platinum – Gold/Platinum Alloys – Rhodium – Graphite – Palladium – Silver – Silver Alloys – Titanium – Silver Filled Elastomers – Silver Filled Coatings
2	Rhodium – Graphite – Palladium – Silver – Silver Alloys – Titanium – Nickel – Monel – Cobalt – Nickel and Cobalt Alloys – Nickel Copper Alloys – AISI 300 Series Steels – A286 Steel – Silver Filled Elastomers – Silver Filled Coatings
3	Titanium – Nickel – Monel – Cobalt – Nickel and Cobalt Alloys – Nickel Copper Alloys – Copper – Bronze – Brass – Copper Alloys – Silver Solder – Commercial Yellow Brass and Bronze – Lead Brass and Bronze – Naval Brass – Steels AISI 300 Series, 451, 440, AM 355 and PH hardened – Chromium Plate – Tungsten – Molybdenum – Certain Silver Filled Elastomers
4	Lead Brass and Bronze – Naval Brass – Steels AISI 431, 440, 410, 416, 420, AM 355 and PH hardened – Chromium Plate – Tungsten – Molybdenum – Tin-Indium – Tin Lead Solder – Lead – Lead Tin Solder – Aluminum 2000 and 7000 Series – Alloy and Carbon Steel – Certain Silver Filled Elastomers – CHO-SHIELD 2000 Series Coatings
5	Chromium Plate – Tungsten – Molybdenum – Steel AISI 410, 416, 420, Alloy and Carbon – Tin – Indium – Tin Lead Solder – Lead – Lead Tin Solder – Aluminum – All Aluminum Alloys – Cadmium – Zinc – Galvanized Steel – Beryllium – Zinc Base Castings
6	Magnesium – Tin

\* Each of these groups overlaps, making it possible to safely use materials from adjacent groups.

flanges is ARP 1481, developed and published by SAE's Committee AE-4 (Electromagnetic Compatibility).

When a finish is required to make two mating metals compatible, finish the metal which is found in the lower numbered grouping of Table II. Metals given in Table II will, because of their inherent corrodibility, already be finished and the finish metal will be subject to the same rule. For example, to couple metals separated by two or more groups (e.g., 4 to 2), find a finish which appears in Group 3 and 4. The Group 3 metal should be plated onto the Group 2 metal to make metals 2 and 4 compatible. The reason for this is, if the finish metal breaks down, or is porous, its area will be large in comparison to the exposed area of the Group 2 metal, and the galvanic corrosion will be less.

On aluminum, chromate conversion coatings (such as Iridite) can be considered as conductive finishes. MIL-C-5541 Class 3 conversion coatings are required to have less than 200 milliohms resistance when measured at 200 psi contact pressure after 168 hours of exposure to a 5 percent salt spray. Recommended MIL-C-5541 Class 3 coatings are Alodine 600, or Alodine 1200 and 1200S dipped.

### Organic Finishes

Organic finishes have been used with a great deal of success to prevent corrosion. Many organic finishes can be used, but none will be effective unless properly applied. The following procedure has been used with no traces of corrosion after 240 hours of MIL-STD-810B salt fog testing.

Aluminum panels are cleaned with a 20% solution of sodium hydroxide and then chromate conversion coated per MIL-C-5541 Class 3 (immersion process). The conversion coated panels are then coated with MIL-C-46168 Type 2 urethane coating, except in the areas where contact is required. For maximum protection of aluminum flanges, a CHO-SHIELD 2000 series conductive coating and CHO-SEAL 1298 conductive elastomer gasket material are recommended. For additional information, refer to Design Guides for Corrosion Control on page 201.

The finish coat can be any suitable urethane coating that is compatible with the MIL-C-46168 coating. It is important to note that test specimens without the MIL-C-46168 coating will show some signs of corrosion, while coated test specimens will show no traces of corrosion.

### CHO-SHIELD® 2000 Series Coatings

When using CHO-SHIELD 2000 series conductive urethane coatings, not enough can be said about surface preparation to attain maximum adhesion. The easily mixed three-component system allows minimum waste with no weighing of components, thus eliminating weighing errors. Because of the filler loading of the 2000 series coatings, it is recommended that an air agitator cup be incorporated into the spray system to keep the conductive particles in suspension during the spraying sequence. It is recommended that approximately 7 mils of wet coating be applied. This thickness can be achieved by spraying multiple passes, with a ten minute wait between passes.

A 7-mil wet film coating will yield a dry film thickness of 4 mils, which is the minimum thickness required to attain the necessary corrosion and electrical values referenced in Chomerics' Technical Bulletin 30. The coating thickness plays an important role in the electrical and corrosion properties. Thinner coatings of 1-3 mils do not exhibit the corrosion resistance of 4-5 mil coatings.

The coating will be smooth to the touch when cured. It is recommended that the coating be cured at room temperature for 2 hours followed by 250°F +/-10°F for one-half hour whenever possible. Alternate cure cycles are available, but with significant differences in corrosion and electrical properties. Two alternate cure schedules are two hours at room temperature followed by 150°F for two hours, or 7 days at room temperature.

Full electrical properties are achieved at room temperature after 7 days. It should be noted that the 250°F cure cycle reflects the ultimate in corrosion resistance properties. The 150°F/2 hour and room temperature/7 day cures will provide less corrosion resistance

than the 250°F cure, but are well within the specification noted in Technical Bulletin 30.

## 1091 Primer

Because of the sensitivity of surface preparation on certain substrates and the availability of equipment to perform the etching of aluminum prior to the conversion coating, Chomerics has introduced 1091 primer, which is an adhesion promoter for CHO-SHIELD 2000 series coatings. When used in conjunction with an alkaline etch or chemical conversion coating per MIL-C-5541 Class 3, the 1091 primer will provide maximum adhesion when correctly applied. (See Technical Bulletin 31.) This primer is recommended only for the 2000 series coatings on properly treated aluminum and is not recommended for composites.

For further assistance on the application of CHO-SHIELD 2000 series coatings on other metallic and non-metallic substrates, contact Chomerics' Applications Engineering Department.

## Galvanic Corrosion

The most common corrosion concern related to EMI gaskets is *galvanic corrosion*. For galvanic corrosion to occur, a unique set of conditions must exist: two metals capable of generating a voltage between them (any two unlike metals will do), electrically joined by a current path, and immersed in a fluid capable of dissolving the less noble of the two (an electrolyte). In short, the conditions of a battery must exist. When these conditions do exist, current will flow and the extent of corrosion which will occur will be directly related to the total amount of current the galvanic cell produces.

When an EMI gasket is placed between two metal flanges, the first condition is generally satisfied because the flanges will probably not be made of the same metal as the gasket (most flanges are

aluminum or steel, and most EMI gaskets contain Monel, silver, tin, etc.). The second condition is satisfied by the inherent conductivity of the EMI gasket. The last condition could be realized when the electronic package is placed in service, where salt spray or atmospheric humidity, if allowed to collect at the flange/gasket interface, can provide the electrolyte for the solution of ions.

Many users of EMI gaskets select Monel mesh or Monel wire-filled materials because they are often described as "corrosion-resistant." Actually, they are only corrosion-resistant in the sense that they do not readily oxidize over time, even in the presence of moisture. However, in terms of electrochemical compatibility with aluminum flanges, Monel is extremely active and its use requires extensive edge sealing and flange finish treatment to prevent galvanic corrosion. Most galvanic tables do not include Monel, because it is not a commonly used structural metal. The galvanic table given in MIL-STD-1250 does include Monel, and shows it to have a 0.6 volt potential difference with respect to aluminum – or almost the same as silver.

A common misconception is that all silver-bearing conductive elastomers behave galvanically as silver. Experiments designed to show the galvanic effects of silver-filled elastomer gaskets in aluminum flanges have shown less corrosion than predicted. Silver-plated-aluminum filled elastomers exhibit the least traces of galvanic corrosion and silver-plated-copper filled elastomers exhibit more. (See Table III).

Tables of galvanic potential do not accurately predict the corrosivity of metal-filled conductive elastomers because of the composite nature of these materials. Also, these tables do not measure directly two important aspects of conductive elastomer "corrosion resistance": 1) the corrosion of the mating metal flange

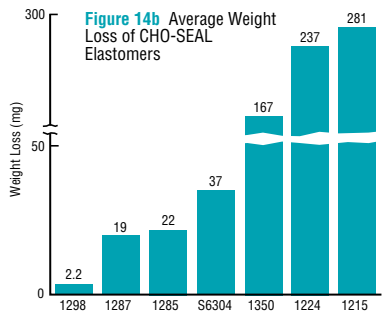
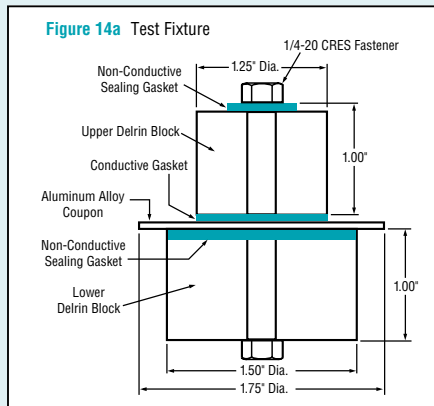
Table III

CORROSION POTENTIALS OF VARIOUS METALS AND EMI GASKET MATERIALS (in 5% NaCl at 21°C after 15 minutes of immersion)	
Material	E <sub>corr</sub> vs. SCE* (Millivolts)
Pure Silver	-25
Silver-filled elastomer	-50
Monel mesh	-125
Silver-plated-copper filled elastomer	-190
Silver-plated-aluminum filled elastomer	-200
Copper	-244
Nickel	-250
Tin-plated Beryllium-copper	-440
Tin-plated copper-clad steel mesh	-440
Aluminum* (1100)	-730
Silver-plated-aluminum filled elastomer (die-cut edge)	-740

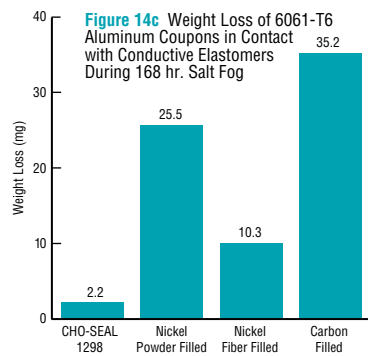
\*Standard Calomel Electrode. Aluminum Alloys approximately -700 to -840 mV vs. SCE in 3% NaCl. Mansfield, F. and Kenkel, J.V., "Laboratory Studies of Galvanic Corrosion of Aluminum Alloys," **Galvanic and Pitting Corrosion – Field and Lab Studies**, ASTM STP 576, 1976, pp. 20-47.

and 2) the retention of conductivity by the elastomer after exposure to a corrosive environment.

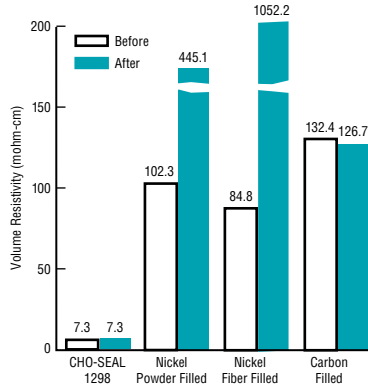
Instead of using a table of galvanic potentials, the corrosion caused by different conductive elastomers was determined directly by measuring the weight loss of an aluminum coupon in contact with the conductive elastomer (after exposure to a salt fog environment). The electrical stability of the elastomer was determined by measuring its resistance before and after exposure. Figure 14a describes the test fixture that was used. Figure 14b shows the aluminum weight loss results for several different silver-filled conductive elastomers. The aluminum weight loss shows a two order of magnitude difference between the least corrosive (1298 silver-plated-aluminum) and most corrosive (1215 silver-plated-copper) filled elastomers. For silver-containing elastomers, the filler



**CHO-SEAL Material**  
(for composition, see Specifications Table, pgs. 32-34.)



**Figure 14d** Volume Resistivity (mohm-cm) of Conductive Elastomers Before and After 168 hr. Salt Fog Exposure



substrate that the silver is plated on is the single most important factor in determining the corrosion caused by the conductive elastomer.

Figure 14c shows the weight loss results for nickel and carbon-filled elastomers compared to 1298. The nickel-filled materials are actually *more* corrosive than the silver-plated-aluminum filled elastomers. The carbon-filled materials are extremely corrosive.

Figure 14d compares the electrical stability of several conductive elastomers before and after salt fog exposure. In general, silver-containing elastomers are more electrically stable in a salt fog environment than nickel-containing elastomers.

### Design Guides for Corrosion Control

The foregoing discussion is not intended to suggest that corrosion should be of no concern when flanges are sealed with silver-bearing conductive elastomers. Rather, corrosion control by and large presents the same problem whether the gasket is silver-filled, Monel wire-filled, or tin-plated. Furthermore, the designer must understand the factors which promote galvanic activity and strive to keep them at safe levels. By “safe”, it should be recognized that some corrosion is likely to occur (and may be generally tolerable) at the outer (unsealed) edges of a flange after long-term exposure to salt-fog environments. This is especially true if proper attention has not been given to flange materials and finishes. The objective should be control of corrosion within acceptable limits.

The key to corrosion control in flanges sealed with EMI gaskets is proper design of the flange and gasket (and, of course, proper selection of the gasket material). A properly designed interface requires a moisture-sealing gasket whose thickness, shape and compression-deflection characteristics allow it to fill all gaps caused by uneven or unflat flanges, surface irregularities,

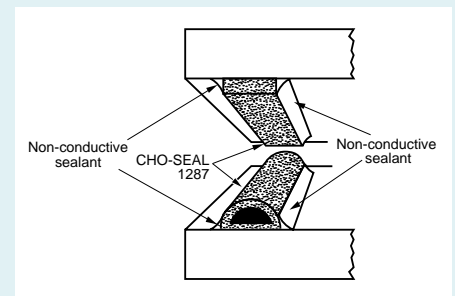
bowing between fasteners and tolerance buildups. If the gasket is designed and applied correctly, it will exclude moisture and inhibit corrosion on the flange faces and inside the package.

Bare aluminum and magnesium, as well as iridized aluminum and magnesium, can be protected by properly designed conductive elastomer gaskets. It is important to note that magnesium is the least noble structural metal commonly used, and a silver-filled elastomer in contact with magnesium would theoretically produce an unacceptable couple.

Some specific design suggestions for proper corrosion control at EMI flanges are:

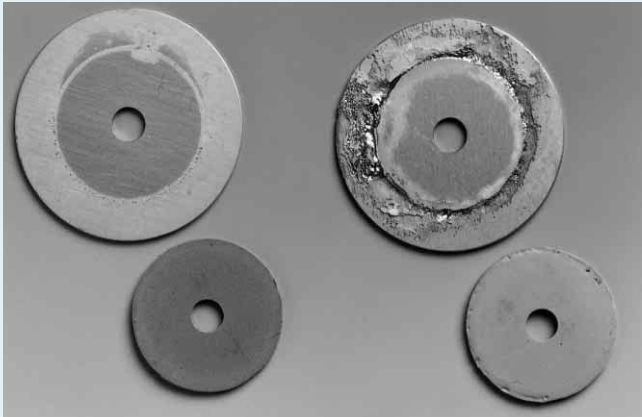
1. Select silver-plated-aluminum filled elastomers for best overall sealing and corrosion protection. CHO-SEAL 1298 material offers more corrosion resistance than any other silver-filled elastomer (see Figure 15, next page).

2. For aircraft applications, consider “seal-to-seal” designs, with same gasket material applied to both flange surfaces (see Figure 16).

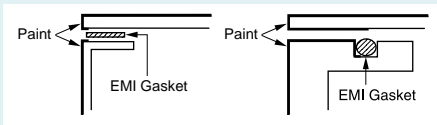


**Figure 16** “Seal-to-seal” design incorporating CHO-SEAL® 1287 conductive silver-aluminum fluorosilicone gaskets on both mating flange surfaces. Gaskets are bonded and edge sealed to prevent moisture from entering the gasket/flange area.

3. To prevent corrosion on outside edges exposed to severe corrosive environments, use dual conductive/non-conductive gaskets (see page 55) or allow the non-conductive protective paint (normally applied to outside surfaces) to intrude slightly under the gasket (see Figure 17).



**Figure 15** Comparison of corrosion results obtained from CHO-SEAL® 1298 conductive elastomer (left) and pure silver-filled elastomer (right) mated with aluminum after 168 hours of salt fog exposure.



**Figure 17** Non-Conductive Paint Intrudes Slightly Under Gasket to Provide Edge Protection

4. If moisture is expected to reach the flange interfaces in Class C (marine) environments, flange surfaces should be coated or plated to make them more compatible with the EMI gasket material. Chomerics' CHO-SHIELD 2000 series coatings are recommended for silver-filled elastomer or Monel wire gaskets, and tin plating for tin-plated gaskets.

5. Avoid designs which create sump areas.

6. Provide drainage and/or drain holes for all parts which would become natural sumps.

7. Provide dessicants for parts which will include sumps but cannot be provided with drain holes. Dessicant filters can also be provided for air intake.

8. Avoid sharp edges or protrusions.

9. Select proper protective finishes.

The definition of a "safe" level of galvanic activity must clearly be expanded to include the requirements of the design. If all traces of corrosion must be prevented (e.g., airframe applications) the structure must be properly finished or must be made

of materials which will not corrode in the use environment. In these cases, the outside edges of EMI-gasketed flanges might also require peripheral sealing as defined in MIL-STD-1250, MIL-STD-889 or MIL-STD-454. MIL-STD-1250 deserves special mention. Although it was developed many years

prior to the availability of CHO-SEAL 1298 conductive elastomer and CHO-SHIELD 2000 series conductive coatings, it offers the following useful corrosion control methods applicable to electronic

enclosures:

1. Bonds made by conductive gaskets or adhesives, and involving dissimilar contact, shall be sealed with organic sealant.

2. When conductive gaskets are used, provision shall be made in design for environmental and electromagnetic seal. Where practical, a combination gasket with conductive metal encased in resin or elastomer shall be preferred.

3. Attention is drawn to possible moisture retention when sponge elastomers are used.

4. Because of the serious loss in conductivity caused by corrosion, special precautions such as environmental seals or external sealant bead shall be taken when wire mesh gaskets of Monel or silver are used in conjunction with aluminum or magnesium.

5. Cut or machined edges of laminated, molded, or filled plastics shall be sealed with impervious materials.

6. Materials that "wick" or are hygroscopic (like sponge core mesh gaskets) shall not be used.

7. In addition to suitability for the intended application, nonmetallic materials shall be selected which have the following characteristics:

- a. Low moisture absorption;
- b. Resistance to fungi and microbial attack;

c. Stability throughout the temperature range;

d. Freedom from outgassing;

e. Compatibility with other materials in the assembly;

f. Resistance to flame and arc;

g. For outdoor applications, ability to withstand weathering.

## Selection of Seal Cross Section

Selection of the proper conductive elastomer gasket cross section is largely one of application, compromise, and experience with similar designs used in the past. Some general rules, however, can be established as initial design guidelines in selecting the class of gasket to be used.

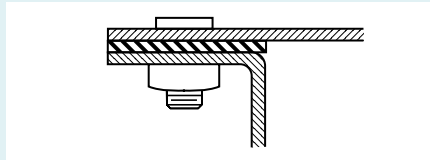
### 1. Flat Gaskets

When using flat gaskets, care must be taken not to locate holes closer to the edge than the thickness of the gasket, or to cut a web narrower than the gasket thickness. This is not to be confused with the criteria for punching holes in sheet metal parts discussed earlier.

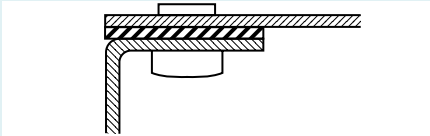
Keep in mind also that flat gaskets should not be deflected more than about 10 percent, compared with 15 to 30 percent for molded and solid extruded gaskets and 50% for hollow gaskets. Standard thicknesses for flat gaskets are 0.020, 0.032, 0.062, 0.093 and 0.125 in. (see General Tolerances on page 204.)

Where possible, the flange should be bent outward so that the screws or bolts do not penetrate the shielded compartment (see Figure 18a). If the flange must be bent inward to save space, the holes in the gasket must fit snugly around the threads of the bolts to prevent leakage along the threads and directly into the compartment. This calls for closely toleranced holes and accurate registration between the holes in the flange and the holes in the gasket, and would require machined dies (rather than rule dies) to produce the gasket. An alternate solution can be achieved by adding an EMI seal under the heads of bolts penetrating the

enclosure, or by using an insert similar to an acorn nut that has been inserted in the flange and flared to make the joint RF-tight. "Blind nuts" can also be welded or attached with a conductive epoxy adhesive (see Figure 18b).



**Figure 18a** External Bolting Prevents EMI Leakage

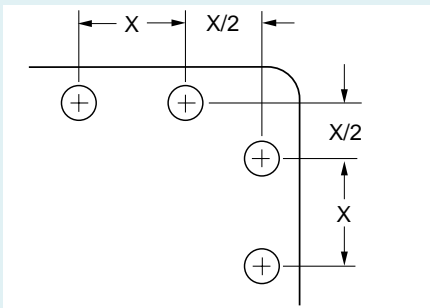


**Figure 18b** Insert Pressed-In and Flared Makes EMI Tight Joint (Alternate: Weld or Cement with Conductive Epoxy)

## 2. Shaped or Molded Gaskets

Groove designs for O- or D-shaped configurations are effective because gasket deflection can be controlled and larger deflections can be accommodated. O-ring cross sections are preferred because they can be deflected more easily under a given load. D-shapes or rectangular cross sections are excellent for retrofit applications because they can be made to accommodate almost any groove cross section. Groove designs also provide metal-to-metal flange contact, and require fewer fasteners, thereby minimizing the number of paths where direct leakage can occur.

Fasteners should be located such that pressure distribution is uniform at the corners (see Figure 19).



**Figure 19** Fastener Location Near Corners

Deflection Range	W Dia.	Deflection Range	H	Deflection Range	T	Deflection Range	A
0.007-0.018 (0.178-0.457)	0.070 (1.778)	0.006-0.012 (0.152-0.305)	0.068 (1.727)	0.001-0.002 (0.025-0.051)	0.020 (0.508)	0.025-0.080 (0.635-2.032)	0.200 (5.08)
0.010-0.026 (0.254-0.660)	0.103 (2.616)	0.008-0.016 (0.203-0.406)	0.089 (2.261)	0.001-0.003 (0.025-0.076)	0.032 (0.813)	0.030-0.125 (0.762-3.175)	0.250 (6.35)
0.013-0.031 (0.330-0.787)	0.125 (3.175)	0.012-0.024 (0.305-0.610)	0.131 (3.327)	0.003-0.006 (0.076-0.152)	0.062 (1.575)	0.075-0.250 (1.905-6.35)	0.360 (9.144)
0.014-0.035 (0.356-0.889)	0.139 (3.531)	0.014-0.029 (0.356-0.737)	0.156 (3.962)	0.003-0.009 (0.076-0.229)	0.093 (2.362)		
		0.016-0.032 (0.406-0.813)	0.175 (4.445)				

**Figure 20** Gasket Deflection Ranges

(mm dimensions in parentheses)

## 3. Hollow Gaskets

Hollow gasket configurations are very useful when large gaps are encountered, or where low closure forces are required. Hollow gaskets are often less expensive, and they can be obtained with or without attachment tabs. Hollow gaskets with tabs are referred to in the text and in the tables as "P-gaskets". The minimum wall thickness of hollow gaskets is 0.020 in. depending on material. Contact Chomerics' Applications Department for details. Hollow gaskets will compensate for a large lack of uniformity between mating surfaces because they can be compressed to the point of eliminating the hollow area.

## 4. Compression Limits

When compression cannot be controlled, compression stops should be provided to prevent gasket rupture caused by over-compression. Grooves provide built-in compression stops. Figure 20 gives nominal recommended compression ranges for CHO-SEAL and CHO-SIL materials, assuming standard tolerances.

## 5. Elongation

The tensile strength of conductive elastomer gaskets is not high. It is good practice to limit elongation to less than 10 percent.

## 6. Splicing

When grooves are provided for gasket containment, two approaches are possible. A custom gasket can

be molded in one piece and placed into the desired groove, or a strip gasket can be spliced to length and fitted to the groove. To properly seat a spliced solid "O" cross section gasket, the inner radius of the groove at the corners must be equal to or greater than the gasket cross section width. Other cross sections need greater inner radius and may not be practical due to twisting when bent around corners. Splices can be simply butted (with no adhesive) or bonded with a conductive or non-conductive compound. If it has been decided that a spliced gasket will provide a satisfactory seal, the decision between splicing and molding should be based on cost. When a standard extrusion is available, splicing is generally recommended. For custom extrusions, splicing is generally more cost effective in quantities over 500 feet.

## 7. Gasket Limitations Imposed by Manufacturing Methods

Current manufacturing technology limits conductive elastomer gasket configurations to the following dimensions and shapes :

### ■ Die-cut Parts

Maximum Overall Size: 32 in. long x 32 in. wide x 0.125 in. thick (81 cm x 81 cm x 3.18 mm)

Minimum Cross Section: Width-to-thickness ratio 1:1 (width is not to be less than the thickness of the gasket).

**Molded Parts**

Currently available in any solid cross section, but not less than 0.040 in. in diameter. The outer dimensions of the gasket are limited to 34 inches in any direction. Larger parts can be made by splicing. Molded parts will include a small amount of flash (0.008 in. width and 0.005 in. thickness, maximum).

**Extruded Parts**

No limitation on length. Minimum solid cross-section is limited to 0.028 in. extrusions. Wall thickness of hollow extrusions varies with material but 0.020 in. can be achieved with most materials.

**8. General Tolerances**

The following tables provide general tolerances for conductive elastomer gaskets. It is important to note that all flat die-cut, molded, and extruded gaskets are subject to free-state variation in the unrestrained condition. The use of inspection fixtures to verify conformance of finished parts is common and recommended where appropriate.

Also note that "Over-all Dimensions" for flat die-cut gaskets and molded gaskets includes any feature-to-feature dimensions (e.g., edge-to-edge, edge-to-hole, hole-to-hole).

MOLDED GASKETS <i>inch (mm)</i>	TOLERANCE
<b>Overall Dimensions</b>	
0.100 to 1.500 (2.54 to 38.10)	±0.010 (0.25)
1.501 to 2.500 (38.13 to 63.50)	±0.015 (0.38)
2.501 to 4.500 (63.53 to 114.30)	±0.020 (0.51)
4.501 to 7.000 (114.33 to 177.80)	±0.025 (0.64)
>7.000 (>177.80)	±0.35% Nom. Dim.
<b>Cross Section</b>	
0.040 to 0.069 (1.02 to 1.75)	±0.003 (0.08)
0.070 to 0.100 (1.78 to 2.54)	±0.004 (0.11)
0.101 to 0.200 (2.57 to 5.08)	±0.005 (0.13)
0.201 to 0.350 (5.11 to 8.89)	±0.008 (0.20)
<b>Flash Tolerance</b>	
	0.005 (0.13) Max.Thickness 0.008 (0.20) Max. Extension

EXTRUDED STRIP GASKETS <i>inch (mm)</i>	TOLERANCE
<b>Cut Length</b>	
<1.000 (25.40)	±0.010 (0.25)
1.0 to 30.000 (25.40 to 762)	±0.062 (1.58)
> 30.000 (762)	±0.2% Nom. Dim.
<b>Cross Section</b>	
< 0.200 (5.08)	±0.005 (0.13)
0.200-0.349 (5.08-8.86)	±0.008 (0.20)
0.350-0.500 (8.89-12.70)	±0.010 (0.25)
> 0.500 (12.70)	±3% Nom. Dim.

**9. Gasket Cross Section Based on Junction Gaps**

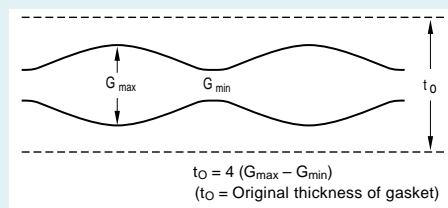
Gasket geometry is largely determined by the largest gap allowed to exist in the junction. Sheet metal enclosures will have larger variations than machined or die castings. The ultimate choice in allowable gap tolerance is a compromise between cost, performance and the reliability required during the life of the device. When a value analysis is conducted, it should be made of the entire junction, including the machining required, special handling, treatment of the surfaces and other factors required to make the junction functional. Often, the gasket is the least expensive item, and contributes to cost-effectiveness by allowing loosely-toleranced flanges to be made EMI-tight.

The maximum gap allowed to exist in a junction is generally determined by the minimum electrical performance expected of the seal. A secondary consideration must be

given to the barrier as a pressure seal if gas pressures of significant magnitude are expected. The gasket will blow out if the pressure is too high for the gap.

The minimum gap allowed in the junction is determined by the allowable squeeze that can be tolerated by the gasket material. Deflection of conductive elastomer gaskets was given in Figure 20. Flat gaskets may be deflected as much as 6-10 percent (nominal), depending on initial thickness and applied force. O-shaped and D-shaped gaskets are normally deflected 10 to 25 percent; however, greater deflections can be achieved by manipulating cross section configuration.

Determination of the exact gasket thickness is a complex problem involving electrical performance, flange characteristics, fastener spacing and the properties of the gasket material. However, an initial estimate of the necessary thickness of a noncontained gasket can be determined by multiplying the difference in the expected minimum and maximum flange gaps by a factor of 4, as illustrated in Figure 21. A more detailed discussion, and a more accurate determination of gasket performance under loaded flange conditions, can be found in the Fastener Requirements section, page 206.



**Figure 21** Gasket Deflection Along a Flange

FLAT DIE-CUT GASKETS <i>inch (mm)</i>	TOLERANCE
<b>Overall Dimensions</b>	
≤10 (254)	±0.010 (0.25)
>10 to ≤15 (254 to 381)	±0.020 (0.51)
>15 (>381)	±0.20% Nom. Dim.
<b>Thickness</b>	
0.020 (0.51)	±0.004 (0.10)
0.032 (0.81)	±0.005 (0.13)
0.045 (1.14)	±0.006 (0.15)
0.062 (1.57)	±0.007 (0.18)
0.093 (2.36)	±0.010 (0.25)
0.125 (3.18)	±0.010 (0.25)
>0.125 (>3.18)	Contact a Chomerics Applications or Sales Engineer
<b>Hole Diameters</b>	
>0.060 (1.52) dia. if sheet thickness is...	
≤0.062 (1.57)	±0.005 (0.13)
>0.062 (1.57)	±0.008 (0.20)